





Standard C

Cementless Hip Prostheses Stems

Standard C Cem

Cemented Hip Prostheses Stems

CE 0482

Explanation of Pictograms			
	Manufacturer		Article number
	Material (number)		Product meets the applicable requirements, which are regulated in the EU harmonization legislation for the affixing of the CE marking.

Standard C

Cementless Hip Prostheses Stems

Standard C Cem

Cemented Hip Prostheses Stems

System Description

- 02 History and philosophy
Materials
- 03 Biomechanical properties

Surgical Technique

- 04 Preoperative planning
Choice of stem size
- 05 Positioning the patient
Resection of the femoral neck
- 06 Preparation of the medullary cavity
- 07 Trial reduction
- 08 Inserting the final stem
- 09 Attaching the final prosthesis head
- 10 Removing the components

Implants

- 11 Sizes: Standard C, Standard C Cem
- 12 Standard C Hip Prosthesis Stems, standard
Standard C Hip Prosthesis Stems, lateralized
- 13 Standard C Cem Hip Prosthesis Stems, standard
Standard C Cem Hip Prosthesis Stems, lateralized

Instruments

- 14 Basic Instrument Set
- 15 Additional instruments
- 16 Instrument Set for anterior / antero-lateral approach
Instrument Set for posterior / postero-lateral approach
- 17 Instrument Set for minimally invasive antero-lateral approach

Accessories

- 18 X-ray Templates

- 19 **Indications - Contraindications**

Important Information

System Description



Fig. 1 - Standard C and Standard C Cem

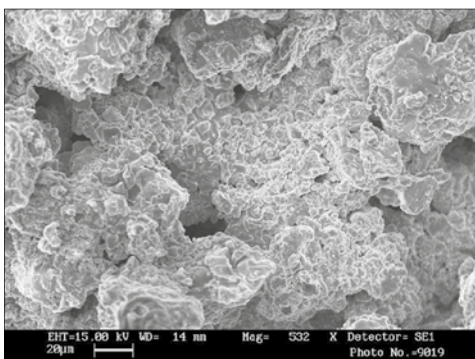

Fig. 2 - corundum-blasted titanium alloy



Fig. 3 - hydroxyapatite coating

History and philosophy

The stems in the Standard C system follow the concept of a straight stem with flattened lateral shoulder.

The straight profile and rectangular cross section of the implant give proximal stability.

The hydroxyapatite coating ensures rapid integration into the bone (Fig.1).

The uncoated version, Standard C Cem (cementable), allows surgeons to change intraoperatively to a cementable stem without requiring a different instrument set.

The cementable and cementless versions are both available in standard (CCD 134°) and lateralized (CCD 131°, + 5 mm offset) forms, see Fig. 1.

Materials

The following materials and coatings are used for hip prosthesis stems of the Standard C and Standard C Cem System:

- The stem of the Standard C is made from forged Ti6Al4V alloy.
- The micro-roughness of the metal surface is created by corundum-blasted particles. This produces a regular and uniform surface structure giving adequate roughness for bone integration (Fig. 2).
- The hydroxyapatite layer (about 55 µm) is applied over the whole length of the prosthesis using the APS (Atmospheric Plasma Spray) process and encourages homogeneous osseointegration (Fig. 3).
- The stem of the Standard C Cem is made from alloy steel FeCrNiMnMoNbN (M30NW) and has a highly polished surface.



Fig. 4
Front view showing 100 mm radius of curvature



Fig. 5
Side view showing metaphyseal V shape



Fig. 6
Taper of the distal tip



Fig. 7
Characteristic proximal and distal ribs

Biomechanical properties

- Large medial curvature with a radius of 100 mm provides metaphyseal support and fixation. This ensures good anatomical fit, essential for good primary stability (Fig. 4).
- Characteristic metaphyseal V-shape with an angle of 8° in AP profile (Fig.5) gives the implant its primary stability.
- Rectangular cross section provides for torsional strength.
- Tapered distal end prevents bone contact and facilitates introduction of the stem into the medullary cavity. Unwanted stress shielding and thigh pain are avoided (Fig. 6).

Standard C

The self-setting shape of the stem has been optimized in the proximal area to encourage mechanical stability and to transmit loading appropriately to the bone surface.

The horizontal ribs on the proximal part oppose subsidence and promote secondary stability. The distal area is equipped with vertical ribs supporting rotational stability (Fig. 7).

Standard C and Standard C Cem

- Flattened tapered neck to increase the range of motion between stem and acetabular cup component.
The 12/14 taper is designed to be used with LINK modular ceramic or metal prosthesis heads of different lengths and diameters.
- The highly polished neck area reduces abrasion of the polyethylene insert if contact should occur.

Surgical Technique



Fig. 13
X-ray with transparent Standard C template

Preoperative planning

For optimal results surgery should be planned in advance using the appropriate templates. The templates are enlarged by a factor of 1 : 1.15.

The size is determined using adequate quality AP and ML X-rays. Each X-ray should be large enough to allow application of the whole template (Abb. 13).

Choice of stem size

The stem size is selected, in the frontal plane, that the outline fills as much of the X-ray proximal femoral metaphyse as possible. In the sagittal plane it must be ensured that the stem is suited to pass the anterior bow of the femur.

The stem is fixed proximally and therefore does not need to fit closely in the distal area. The size of prosthesis should be chosen so that the center of rotation is correctly situated in the middle of the head. Anteversion must be checked in the sagittal plane.

The stem size and the level for resection of the femoral neck should be selected such that the tip of the greater trochanter is level with the center of the head of the prosthesis.

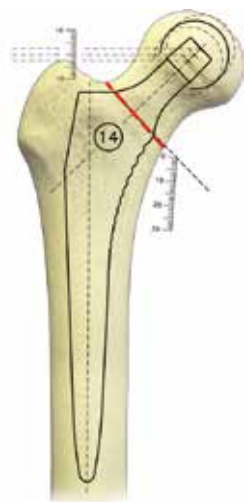

Fig. 14
Standard C,
standard



Fig. 15
Standard C,
lateralized

The templates for the Standard C and the Standard C Cem show the centers of rotation of the two versions (standard and lateralized) for different head lengths. (Fig. 14-15)

Note:
Pre-operative planning gives an initial estimate but cannot conclusively determine the size of stem to be used. This must be decided intra-operatively.



Fig. 16

Positioning the patient

Note:
Fig. 16 shows the normal position for postero-lateral surgical approach.

All the following steps also apply for the supine position and all other surgical access routes. The patient lies on the appropriate side. Make a postero-lateral incision (Fig. 16). Open the fascia lata and resect the external rotator muscles. Then make an incision in the joint capsule. Dislocate the femoral head in a dorsal direction so that it lies free.

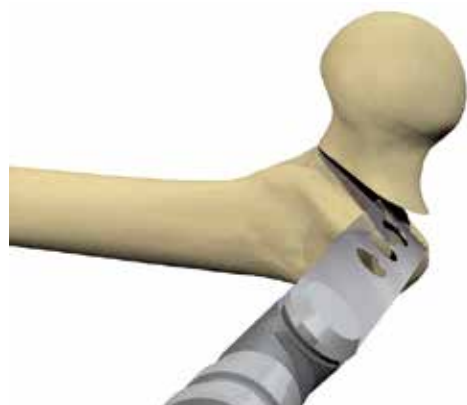

Fig. 17

Resection of the femoral neck

After dislocating the femoral head resect the neck (Fig. 17).



Fig. 18

Preparation of the medullary cavity

Open the medullary cavity and greater trochanter with the box chisel (Fig. 18).



Fig. 19

Then open the medullary cavity with the awl (Fig. 19).



Fig. 20

The Standard C Instrument set contains a series of rasps (Fig. 20). When a posterior/postero-lateral approach is employed they are used with the straight rasp handle, and when the approach is anterior/ antero-lateral they are used with the angled rasp handle.



Rasp handle, straight



Rasp handle, angled



Rasp handle, double-angled, lateral view

Double-angled rasp handles are also available, in both right and left forms, for a minimally invasive antero-lateral approach (Fig. 21).



Rasp handle, double-angled, top view

Fig. 21

To fix the rasp in the rasp handle open the lever and insert the rasp with the medial side facing the lever (Fig. 22).



Fig. 22



Fig. 23

Then close the lever (Fig. 23). Start with the smallest rasp. Consider the correct anteversion angle (usually 15°) in the process.



Fig. 24a

Drive the rasp in until the junction level of the rasp is flush with the resected neck level (Fig. 24 a).

Note:

The resection level is determined during pre-operative planning with the aid of the templates. Any deviations must now be taken into consideration.

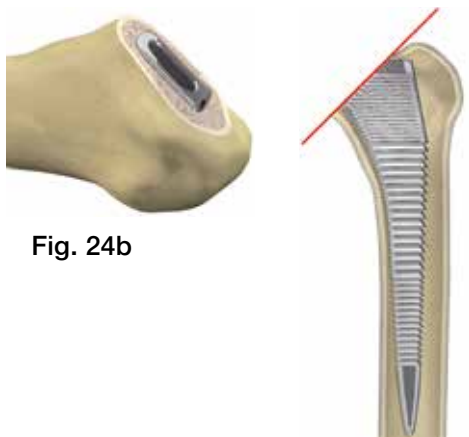

Fig. 24b

Fig. 24c

Continue with progressively larger rasp sizes until the rasp is optimally seated in the stem. When you reach the optimal rasp size (which is not necessarily the same as planned preoperatively) remove the handle and leave the rasp in place (Fig. 24 b, c).



Fig. 25

Trial reduction

The acetabular cup is usually implanted before the stem. Trial reduction can then be carried out.



Fig. 26

The Standard C / Standard C Cem Instrument Set contains trial necks for every size of both versions – standard (green) and lateralized (blue). Choose the trial neck of the same size as the rasp left in situ and fit it on using the neck positioner (Fig. 25-26).



Fig. 27

Place the trial head (Fig. 27) on the trial neck and perform trial reduction (Fig. 28).



Fig. 28

Then remove the trial neck and remove the rasp with the relevant rasp handle.

An optional extractor (see page 07) is available for removal of the trial neck.

Inserting the final stem

The procedure described below applies for both the cementless and cementable versions of the Standard C.

Select a Standard C / Standard C Cem prosthesis stem of the same size as the last rasp used and remove it from the sterile package. Screw the stem impactor onto the final prosthesis stem. (Fig. 29, example with Standard C, cementless).



Fig. 29



Fig. 30

Use the T-shaped handle for attachment (Fig. 30).



Fig. 31

The groove indicates when the stem is completely fixed to the impactor (Fig. 31).

After removing the T-shaped handle, drive the stem up to the same depth into the femur as the final rasp used.

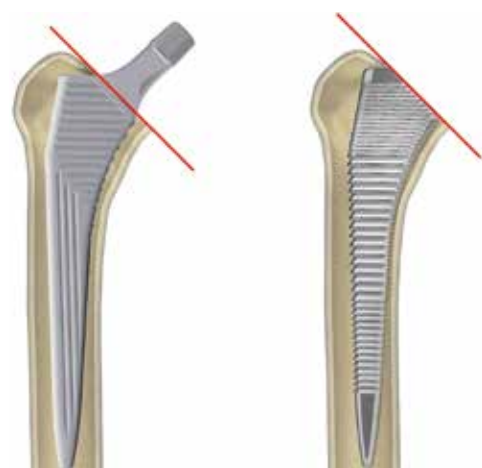

Fig. 32

Procedure for Standard C (cementless)

Ensure that the line between the hydroxyapatite coating and the polished neck surface lies where the profile of the rasp ends when in situ (Fig. 32). Remove the impactor.

Procedure for Standard C Cem (cementable)

After inserting the distal cement restrictor, fill the medullary cavity with bone cement in a retrograde fashion. Then insert the prosthesis stem. In the final state, the transition line between the body and neck of the prosthesis must lie where the profile of the rasp ended when in situ. Remove the impactor.



Fig. 33

Attaching the final prosthesis head

At this point the correct head length can be checked again using the trial heads.

Remove the appropriate prosthesis head (diameter, length, material) from the sterile packaging (Fig. 33).



Fig. 34

Clean and dry the taper of the stem thoroughly. This is particularly important with ceramic heads.

Mount the head by hand using axial pressure and a rotational motion (Fig. 34).



Fig. 35

Impact the head with a short blow (Fig. 35) using the impactor for prosthesis heads (available on request).

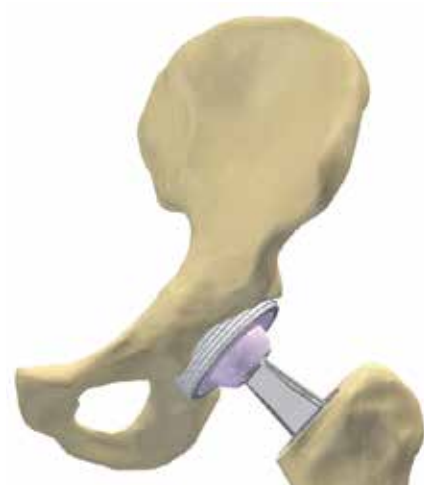

Fig. 36

Clean the joint surfaces thoroughly and then finally reduce the joint (Fig. 36).

Removing the components

Each of the prosthesis components can be removed if necessary.

The prosthesis head can be removed in an axial direction by means of a rod which is placed at the base of the head.



Fig. 37

Caution:

If a ceramic head has to be replaced with another ceramic head, only ceramic revision heads (with a metal inner taper) should be used.

For removal of the prosthesis stem, screw the stem impactor onto the stem. Attach the slap hammer to the impactor (Fig. 37) and drive the implant out.

Implants

Sizes: Standard C and Standard C Cem

The standard and lateralized forms of Standard C are available in 11 sizes and Standard C Cem prosthesis stems are available in 10 sizes.

The CCD angle is 134° in the standard version and 131° in the lateralized version.

The stem measurements increase proportionately with increasing size. In the frontal plane stems increase by 1 mm per size. In the sagittal plane thickness increases by 0.5 mm per size.

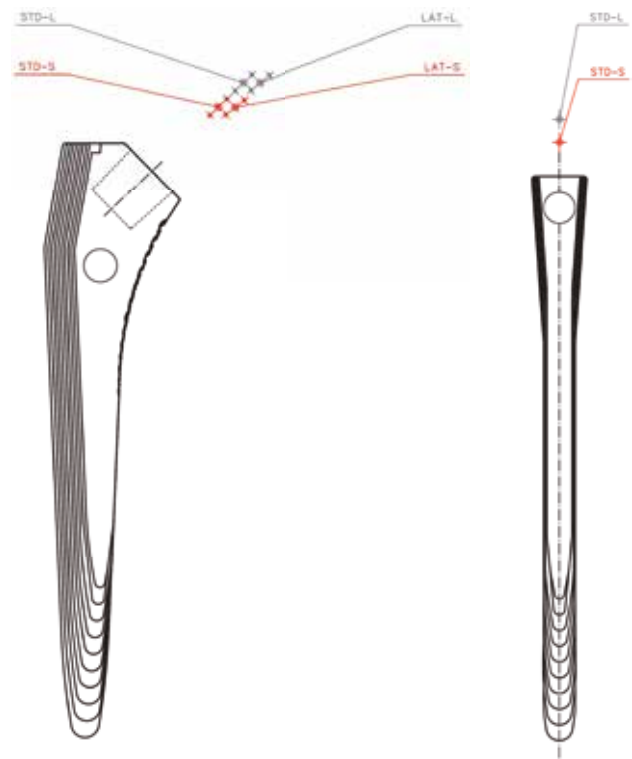
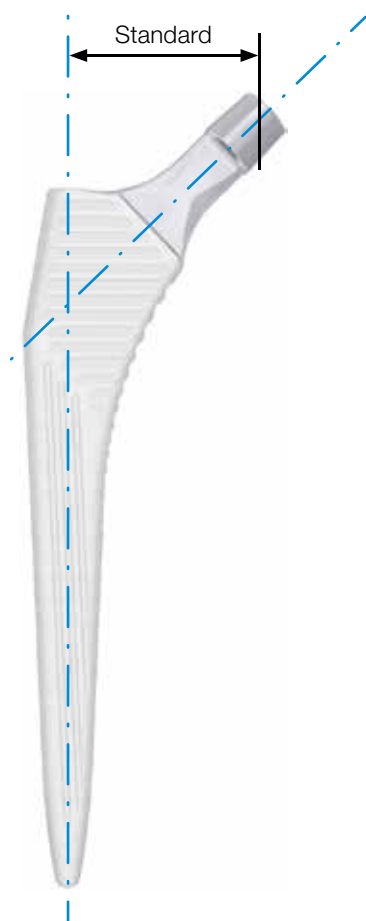

Fig. 38 - Stem sizes and centers of rotation



Standard C hip prosthesis stem, standard

MAT Ti6Al4V, hydroxyapatite coating, taper 12/14, CCD angle 134°

REF	Size
161-000	8
161-001	9
161-002	10
161-003	11
161-004	12
161-005	13
161-006	14
161-007	15
161-008	16
161-009	17
161-010	18

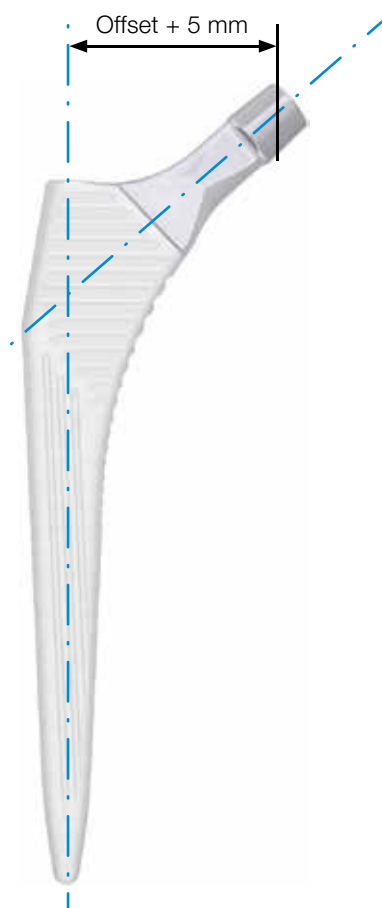

Standard C hip prosthesis stem, lateralized

MAT Ti6Al4V, hydroxyapatite coating, taper 12/14, CCD angle 131°

REF	Size
161-020	8
161-021	9
161-022	10
161-023	11
161-024	12
161-025	13
161-026	14
161-027	15
161-028	16
161-029	17
161-030	18

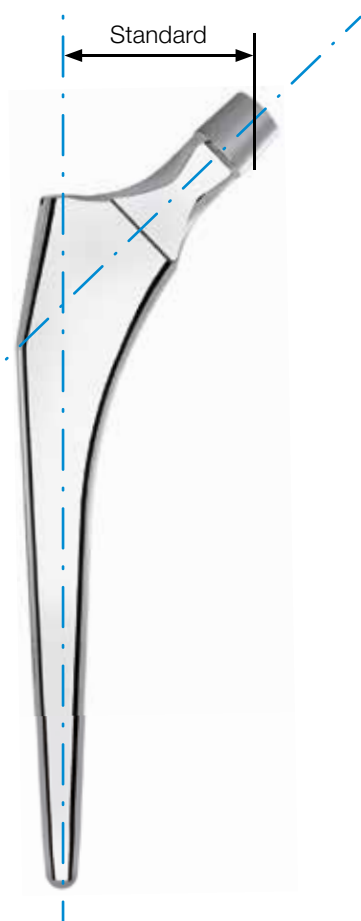

Standard C Cem hip prosthesis stem, standard

[MAT] FeCrNiMnMoNbN (M30NW), taper 12/14, CCD angle 134°

REF	Size
161-501	9
161-502	10
161-503	11
161-504	12
161-505	13
161-506	14
161-507	15
161-508	16
161-509	17
161-510	18

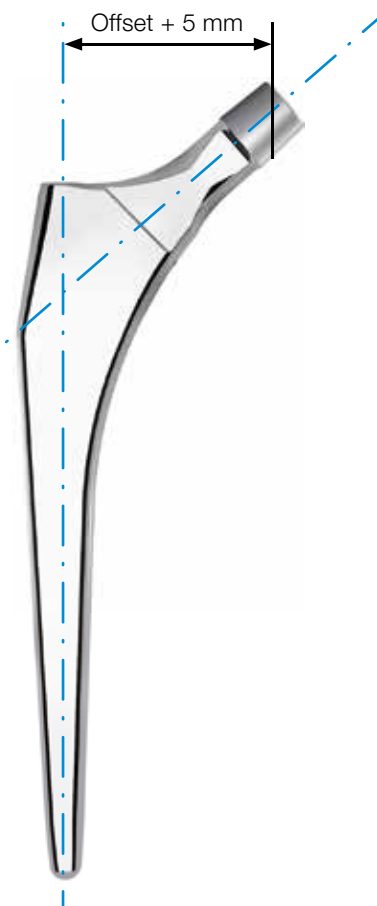

Standard C Cem hip prosthesis stem, lateralized (+ 5 mm Offset)

[MAT] FeCrNiMnMoNbN (M30NW), taper 12/14, CCD angle 131°

REF	Size
161-521	9
161-522	10
161-523	11
161-524	12
161-525	13
161-526	14
161-527	15
161-528	16
161-529	17
161-530	18

Basic Instrument Set

161-100/01 Instrument Set for Standard C & Standard C Cem hip prosthesis stems

161-101/01 Container, sterilizable, empty

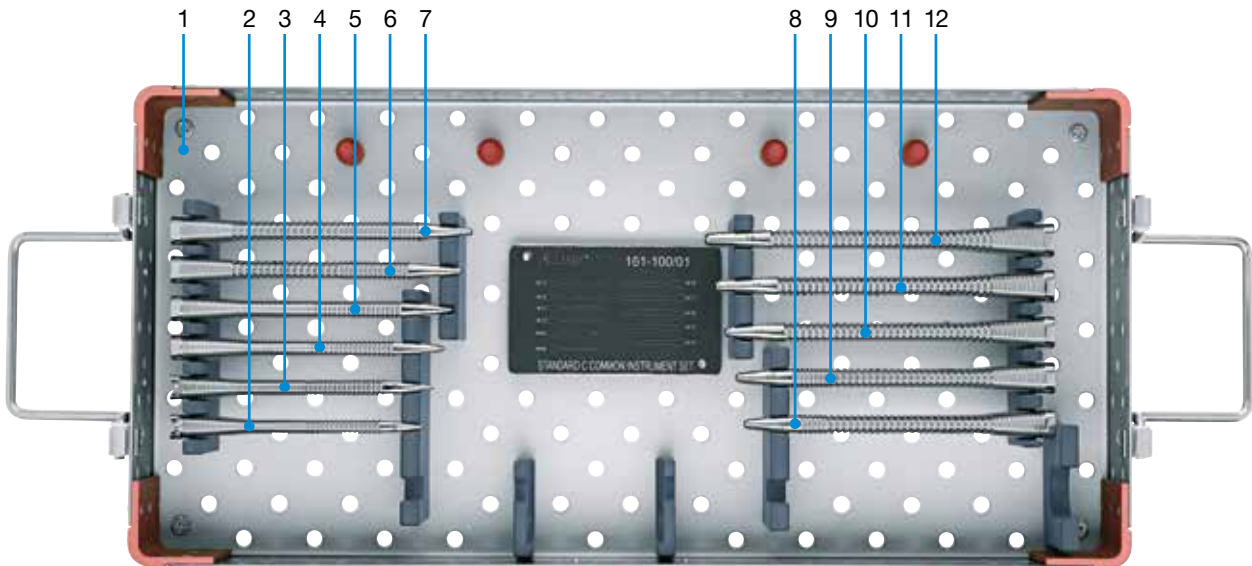

	REF	Description	Qty
1	161-101/01	Container, sterilizable, empty	1
2	161-110/08	Rasp stem, size 08	1
3	161-110/09	Rasp stem, size 09	1
4	161-110/10	Rasp stem, size 10	1
5	161-110/11	Rasp stem, size 11	1
6	161-110/12	Rasp stem, size 12	1
7	161-110/13	Rasp stem, size 13	1
8	161-110/14	Rasp stem, size 14	1
9	161-110/15	Rasp stem, size 15	1
10	161-110/16	Rasp stem, size 16	1
11	161-110/17	Rasp stem, size 17	1
12	161-110/18	Rasp stem, size 18	1
	161-102/01*	Extractor for neck segments*	1*

* not shown, optional

Additional Instruments

- 161-100/10 Instrument Set, additional
- 161-101/04 Container, sterilizable, empty

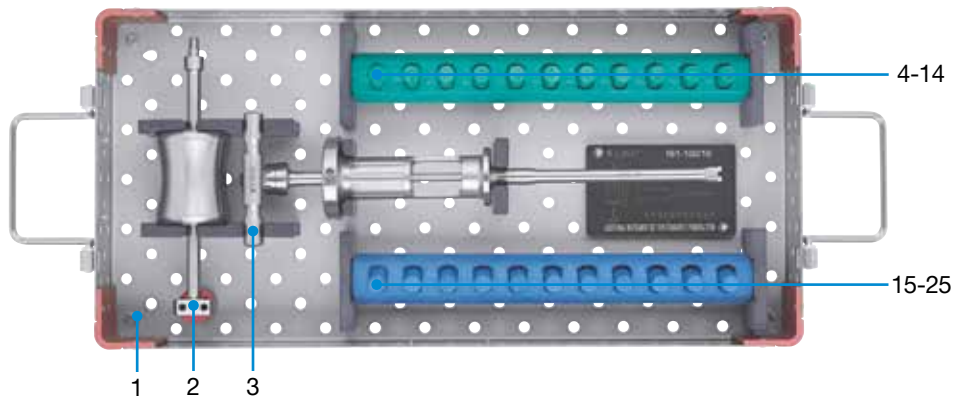

	REF	Description	Size	Qty
1	161-101/04	Container, sterilizable, empty		1
2	162-401/21	Slaphammer		1
3	162-401/11	Stem impactor and extractor for prosthesis stem		1
4	161-104/08	Modular trial neck segment	8	1
5	161-104/09	Modular trial neck segment	9	1
6	161-104/10	Modular trial neck segment	10	1
7	161-104/11	Modular trial neck segment	11	1
8	161-104/12	Modular trial neck segment	12	1
9	161-104/13	Modular trial neck segment	13	1
10	161-104/14	Modular trial neck segment	14	1
11	161-104/15	Modular trial neck segment	15	1
12	161-104/16	Modular trial neck segment	16	1
13	161-104/17	Modular trial neck segment	17	1
14	161-104/18	Modular trial neck segment	18	1
15	161-105/08	Modular trial neck segment, lateralized	8	1
16	161-105/09	Modular trial neck segment, lateralized	9	1
17	161-105/10	Modular trial neck segment, lateralized	10	1
18	161-105/11	Modular trial neck segment, lateralized	11	1
19	161-105/12	Modular trial neck segment, lateralized	12	1
20	161-105/13	Modular trial neck segment, lateralized	13	1
21	161-105/14	Modular trial neck segment, lateralized	14	1
22	161-105/15	Modular trial neck segment, lateralized	15	1
23	161-105/16	Modular trial neck segment, lateralized	16	1
24	161-105/17	Modular trial neck segment, lateralized	17	1
25	161-105/18	Modular trial neck segment, lateralized	18	1

161-100/20 Instrument Set for anterior / antero-lateral approach

161-101/02 Container, sterilizable, empty

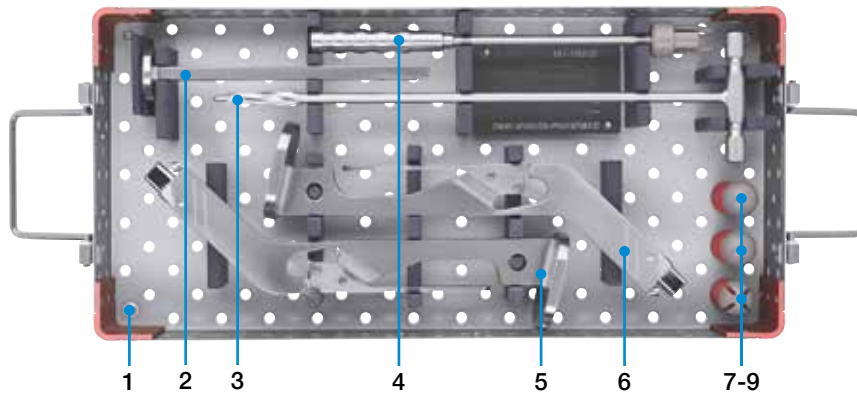

	REF	Description	Qty
1	161-101/02	Container, sterilizable, empty	1
2	162-403/01	Box chisel	1
3	161-106/02	Opening owl	1
4	161-106/04	Positioner for neck section	1
5	161-106/05	Rasp handle and stem positioning instrument, angled	1
6	161-106/05	Rasp handle and stem positioning instrument, angled	1
7	162-428/01	Trial head, Ø 28 mm S	1
8	162-428/02	Trial head, Ø 28 mm M	1
9	162-428/03	Trial head, Ø 28 mm L	1

161-100/30 Instrument Set for posterior / postero-lateral approach

161-101/03 Container, sterilizable, empty

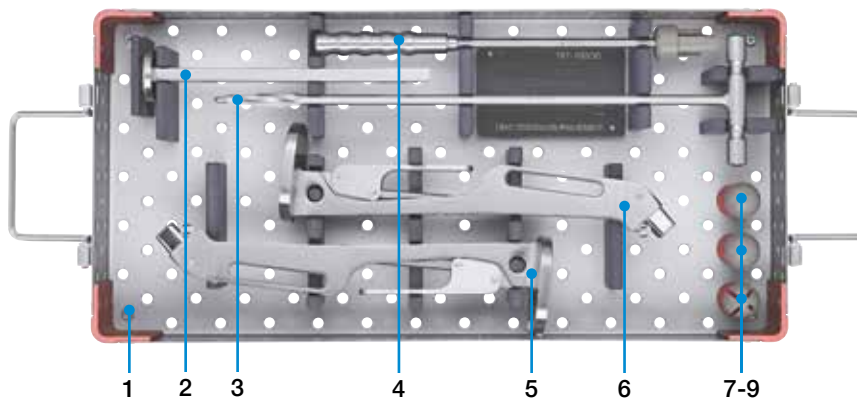

	REF	Description	Qty
1	161-101/03	Container, sterilizable, empty	1
2	162-403/01	Box chisel	1
3	161-106/02	Opening owl	1
4	161-106/04	Positioner for neck section	1
5	161-106/03	Rasp handle and stem positioning instrument, straight	1
6	161-106/03	Rasp handle and stem positioning instrument, straight	1
7	162-428/01	Trial head, Ø 28 mm S	1
8	162-428/02	Trial head, Ø 28 mm M	1
9	162-428/03	Trial head, Ø 28 mm L	1

161-100/40 Instrument Set for anterolateral approach, minimally invasive
161-101/05 Container, sterilizable, empty

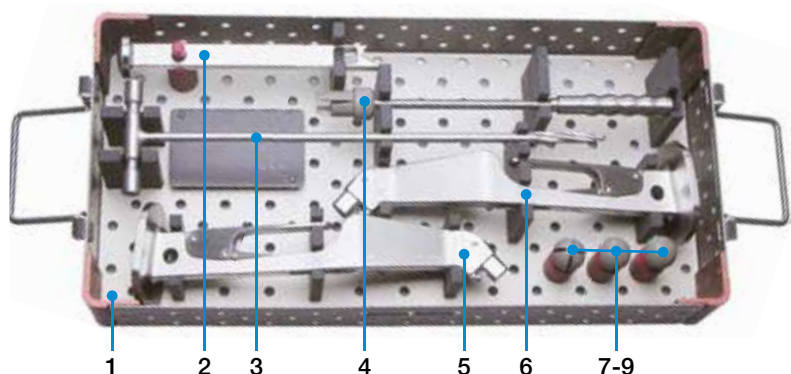

	REF	Description	Qty
1	161-101/05	Container, sterilizable, empty	1
2	162-403/01	Box chisel	1
3	161-106/02	Opening owl	1
4	161-106/04	Positioner for neck section	1
5	161-106/08	Rasp handle, double offset for MI surgery, left	1
6	161-106/09	Rasp handle, double offset for MI surgery, right	1
7	162-428/01	Trial head, Ø 28 mm S	1
8	162-428/02	Trial head, Ø 28 mm M	1
9	162-428/03	Trial head, Ø 28 mm L	1

X-ray Templates

REF	X-ray templates for Standard C hip prosthesis stems, cementless
	Sizes 8 - 18 MAT Ti6Al4V, hydroxyapatite coating, taper 12/14, 115% natural size, set of 11 sheets
161-200/01	for standard version
161-200/02	for lateralizing version

REF	X-ray templates for Standard C Cem hip prosthesis stems, cementless
	Sizes 8 - 18 MAT FeCrNiMnMoNbN (M30NW), taper 12/14, 115% natural size, set of 11 sheets
161-200/03	for standard version
161-200/04	for lateralizing version

Indications - Contraindications

Indications

Monolithic stems are indicated for use in partial or total hip arthroplasty. The uncemented stem LINK Standard prosthesis shaft C is intended for press-fit (uncemented) use, LINK Standard prosthesis shaft C cemented is intended for cemented use.

When used in total hip arthroplasty, they are intended for use with modular heads and compatible acetabular cups. When used in partial hip arthroplasty, they are intended for use with femoral heads intended for partial hip arthroplasty or bipolar heads.

Hip arthroplasty is intended for reduction or relief of pain and/or improved hip function in skeletally mature patients with the following conditions:

- Non-inflammatory degenerative joint disease including osteoarthritis, avascular necrosis and dysplasia;
- Rheumatoid arthritis;
- Treatment of femoral head and neck fractures.

Contraindications

Absolute contraindications include:

- Local or systemic infection;
- Septicaemia;
- Persistent acute or chronic osteomyelitis;
- Confirmed nerve or muscle lesion compromising hip joint function.

Additional contraindication

for Standard C cemented:

- For sizes #9 and #10: patients with mass higher than 71kg.

Relative contraindications include:

- Vascular or nerve diseases affecting the concerned limb;
- Poor bone stock (for example due to osteoporosis or extended previous revision surgery) compromising the stability of the implant;
- metabolic disorders which may impair fixation and stability of the implant;
- any concomitant disease and dependence that might affect the implanted prosthesis;
- metal hypersensitivity to implant materials

Please note the following regarding the use of our implants:

1. Choosing the right implant is very important.

The size and shape of the human bone determine the size and shape of the implant and also limit the load capacity. Implants are not designed to withstand unlimited physical stress. Demands should not exceed normal functional loads.

2. Correct handling of the implant is very important.

Under no circumstances should the shape of a finished implant be altered, as this shortens its life span. Our implants must not be combined with implants from other manufacturers.

The instruments indicated in the Surgical Technique must be used to ensure safe implantation of the components.

3. Implants must not be reused.

Implants are supplied sterile and are intended for single use only. Used implants must not be reused.

4. After-treatment is also very important.

The patient must be informed of the limitations of the implant. The load capacity of an implant cannot compare with that of healthy bone!

5. Unless otherwise indicated, implants are supplied in sterile packaging.

Note the following conditions for storage of packaged implants:

- Avoid extreme or sudden changes in temperature.
- Sterile implants in their original, intact protective packaging may be stored in permanent buildings up until the "Use by" date indicated on the packaging.
- They must not be exposed to frost, dampness or direct sunlight, or mechanical damage.
- Implants may be stored in their original packaging for up to 5 years after the date of manufacture. The "Use by" date is indicated on the product label.
- Do not use an implant if the packaging is damaged.

6. Traceability is important.

Please use the documentation stickers provided to ensure traceability.

7. Further information on the material composition is available on request from the manufacturer.

Follow the instructions for use!

Waldemar Link GmbH & Co. KG, Hamburg

All content in this catalog, including text, pictures and data, is protected by law. Every instance of use, whether in part or in whole and which is not permitted by law, is subject to our prior consent. In particular, this applies to the reproduction, editing, translation, publishing, saving, processing, or passing on of content stored in databases or other electronic media and systems, in any manner or form. The information in the catalogs is solely intended to describe the products and does not constitute a guarantee.

The Surgical Technique described has been written to the best of our knowledge and belief, but it does not relieve the surgeon of his/her responsibility to duly consider the particularities of each individual case.

Products shown in this document may not be available in your country. The product availability is subject to the approval and/or registration regulations of the respective country. Please contact Waldemar Link GmbH & Co. KG if you have questions about the availability of LINK products in your country.

Waldemar Link GmbH & Co. KG and/or other corporate affiliated entities own, use or have applied for the following trademarks in many jurisdictions: LINK, BiMobile, SP II, Modell Lubinus, E-Dur, EndoDur, T.O.P. II, BetaCup, CombiCup PF, CombiCup SC, CombiCup R, MobileLink, C.F.P., LCU, SP-CL, LCP, MIT-H, Endo-Model, Endo-Model SL, MP, MEGASYSTEM-C, GEMINI SL, SPAR-K, LCK, HX, TiCaP, X-LINKed, PorAg, LINK PorEx, BiPorEx, PorEx-Z, TrabecuLink, Tilastan, customLink, RescueSleeve, VACUCAST.

Other trademarks and trade names may be used in this document to refer to either the entities claiming the marks and/or names or their products and are the property of their respective owners.



Waldemar Link GmbH & Co. KG

Barkhausenweg 10 · 22339 Hamburg · Germany

Phone +49 40 53995-0 · info@linkhh.de

www.linkorthopaedics.com

